

# *Ampeg*<sup>®</sup>

## **LIQUIFIER**

---

Analog Chorus

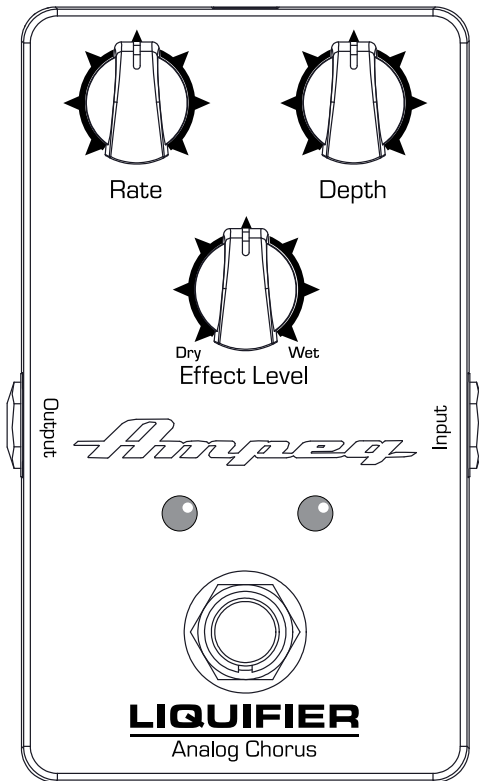

**Owner's Manual**



**TABLE OF CONTENTS**

Introduction .....	2
Features.....	3
Top Panel Features .....	4
Rear and Bottom Panel Features .....	5
Suggested Settings.....	6
Block Diagram .....	8
Technical Specifications .....	9
Warranty and Support .....	9

**Introduction**

The Ampeg Liquifier Analog Chorus pedal delivers incredibly rich tones thanks to its dual chorus circuit design. Experience classic, dreamy chorus, or turn it all the way up to transport your tone to a new dimension. Featuring a roadworthy, all-metal chassis and true bypass switching, the Liquifier Analog Chorus delivers all the lush sounds you’ve been dreaming of, and more.

Like all Ampeg products, your Liquifier Analog Chorus pedal is designed by musicians and built using only the best of components. Each pedal is tested to confirm that it meets our specifications, and we believe that this pedal is the absolute best that it can be.

In order to get the most out of your new pedal, please fully read this *Owner’s Manual*, as well as the *Important Safety Instructions* included with your pedal, before you begin playing. Best of luck in all of your musical endeavors!

And **thank you** for choosing Ampeg.

## Features

- Dual chorus circuit design delivers incredibly rich chorus tones for both bass & guitar
- Dial in the perfect sound with Rate, Depth, and Effect Level controls
- True bypass, analog design with incredible signal-to-noise ratio
- Roadworthy all-metal chassis construction
- 9V DC supply or battery capable (not included)

## **About the Liquifier Analog Chorus**

A chorus effect essentially copies the original signal, slightly alters the timing using delay, and combines it with the original signal. By adjusting various parameters, a wide range of effects may be produced. Just like a chorus of singers, the combination of multiple, slightly differing sources creates blurriness of both pitch and rhythm that makes the sound feel “wider” than the original. When used tastefully, chorus can add a very melodic presence to a bass line. It provides a soft, ethereal sweeping effect that is useful for thickening and for making a particular sound pop out of the mix. It can also be abused for all kinds of great, specialized effects!

But here’s what makes the Ampeg Liquifier Analog Chorus pedal unique:

- Instead of just a single delayed copy of the original signal, the Liquifier makes two copies... and one of those copies is a polarity-inverted mirror image.
- What happens next is that two separate triangle waves vibrate the pitch of the copies. These waves are linked so that as one copy rises sharply in pitch, the other wave falls flat by the same amount. As the pitches criss-cross each other, some high frequencies cancel each other out in a “comb-filtering” effect that rises.
- When the two copies are matched exactly in their pitch-shift, they briefly disappear. This is also known as “through-zero flanging,” a rarity in true-analog effects pedals.
- All three signals (dry + delay + polarity-inverted mirror image) are blended together via the Effect Level knob. The result is signal movement that swirls in a 3-dimensional manner.

Now go impress your friends with this new-found knowledge!

## Top Panel Features

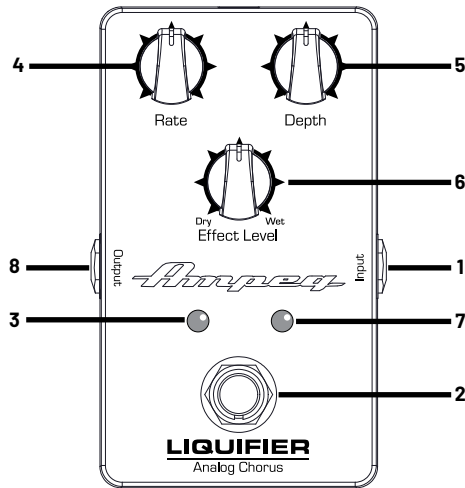

**1. INPUT:** The signal output from an instrument (active or passive) may be connected to this 1/4" Input by means of an unbalanced, (shielded) instrument cable.

**NOTE:** Unplug the input cable when not in use, as the 9V battery will drain (and eventually die). Details on replacing the battery may be found on [page 5](#).

**2. ON/OFF SWITCH:** Engage this switch to activate the Liquifier Analog Chorus pedal. This pedal is true bypass, meaning, the signal will pass through from input to output with no circuitry in between when the switch is disengaged.

**3. ON/OFF LED:** This LED illuminates purple when the pedal is engaged.

**4. RATE:** Rotate this knob to adjust the speed of the low-frequency oscillator (LFO), from minimum (fully counter-clockwise) to maximum (fully clockwise).

**5. DEPTH:** Rotate this knob to adjust the amplitude of the rate, from minimum intensity (fully counter-clockwise) to maximum intensity (fully clockwise).

**6. EFFECT LEVEL:** Rotate this knob to adjust the overall effect level, from Dry (no effect, fully counter-clockwise) to Wet (100% effect, fully clockwise).

**Examples:**

- 9:00 – The swirling takes a subtle back seat to the dry signal.
- 12:00 – With the Effect Level knob at half, the signal becomes a glorious 3-way psychedelic swirl.
- 5:00 (100% wet) – This results in pure, through-zero flanging.

**7. RATE INDICATION LED:** This green LED flashes to indicate the current modulation rate.

**8. OUTPUT:** Typically, this 1/4" output jack connects to the input of your bass amplifier—or powered loudspeakers, as long as they have their own input controls to adjust the volume level—by means of an unbalanced (shielded) instrument cable.

Alternatively, you may connect this Output to an external mixer, recorder, or interface. In this way, you do not have to mic the speaker cabinet in order to add it to the main mix, or to record.

## Rear and Bottom Panel Features

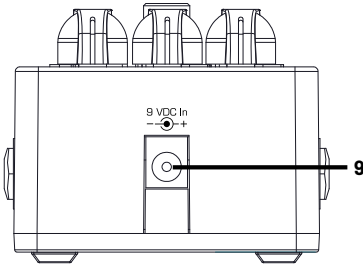

- 9. POWER CONNECTOR:** This is where to connect the optional power supply.

**NOTE:** Before plugging in the power supply, make sure that you are using the correct model power supply for this product. Failure to do so may result in damage to your unit and void your warranty.

A **DC-1G Power Supply** may be purchased from an Ampeg Dealer, or you may purchase one directly from the Ampeg Online Shop, at [shop.ampeg.com](http://shop.ampeg.com).

For residents outside of the US, please request the model **DC-1G Power Supply** when purchasing from an Ampeg dealer or distributor in your region.

### BOTTOM PANEL ACCESS

This is where the 9V battery is housed.

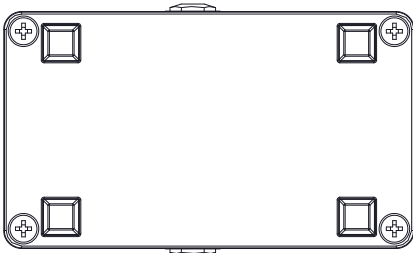

Removing the bottom is easy. Simply start by placing the pedal top down on a soft, dry cloth.

Remove each of the four screws by turning them counter-clockwise. Be sure to keep them in a safe place as you will need them again!

- 10. 9V BATTERY:** The Liquifier Analog Chorus pedal may be powered by 9V battery instead of using a power supply. As seen in the illustration below, it fits nicely inside a compartment of the circuit board, next to the edge of the pedal.

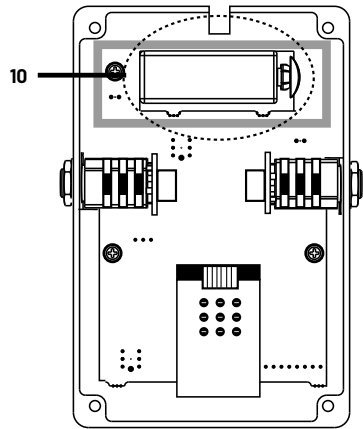

**NOTE:** Unplug the input cable when not in use, as the 9V battery will drain (and eventually die).

**NOTE:** When replacing the bottom of the pedal, line up the rectangular foam piece over the battery. Turn the screws clockwise to affix to the bottom to the pedal.

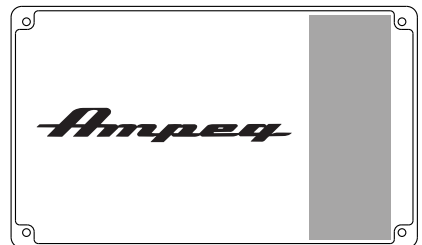

### Suggested Settings

#### Believing (Don't Stop)

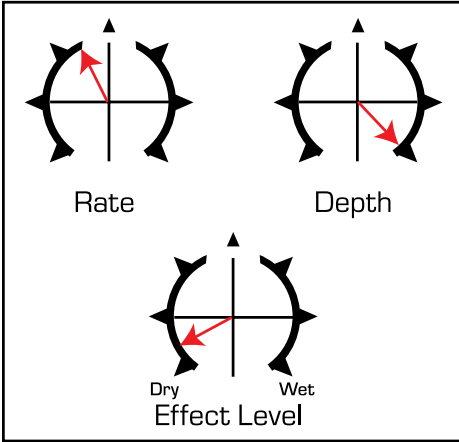

#### Nice & Easy

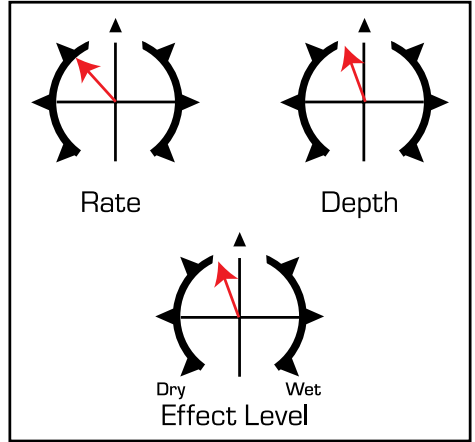

#### Space Invaderz

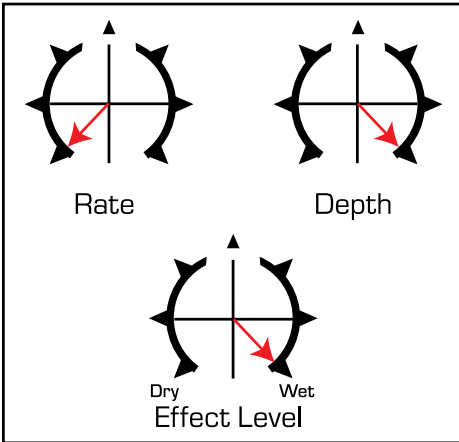

#### Nice Tremolo

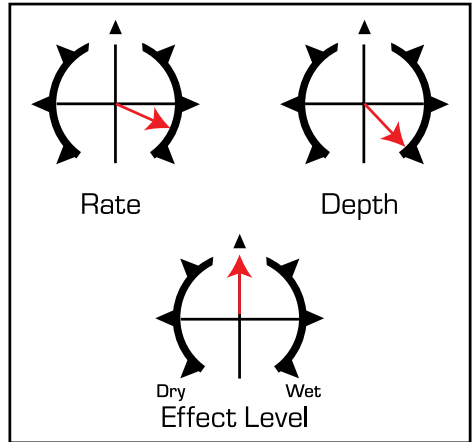

### Suggested Settings - Continued

#### Hollow

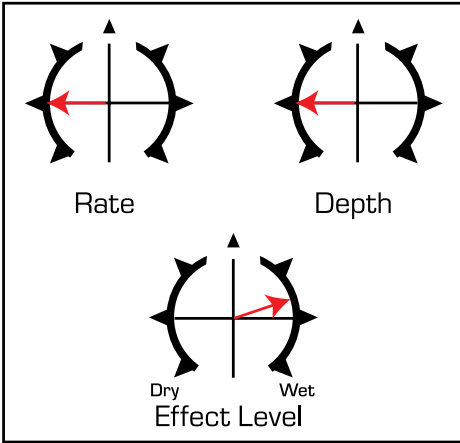

#### In & Out

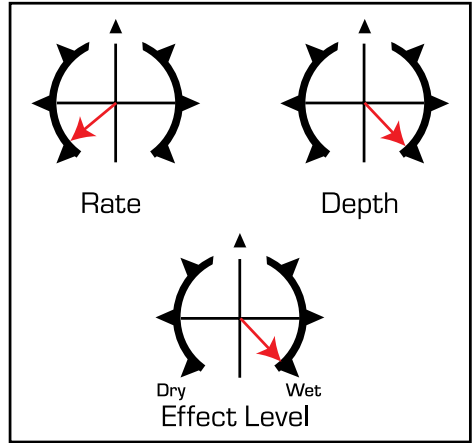

#### Inverted

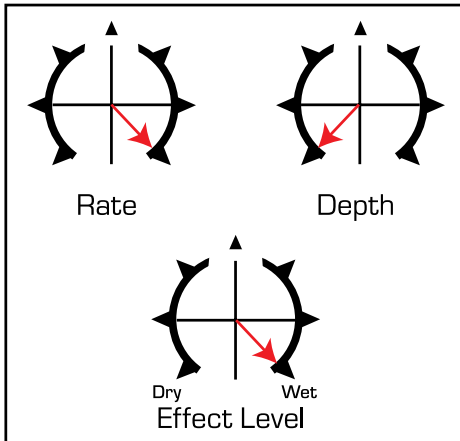

#### Warbly

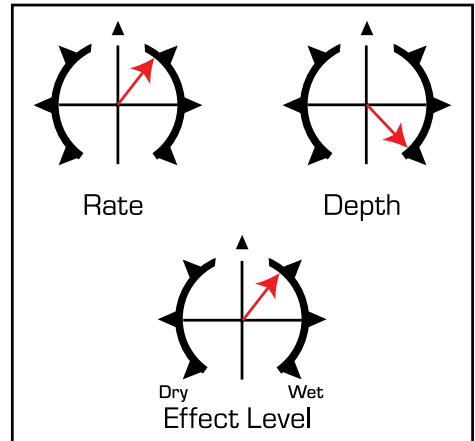

Block Diagram

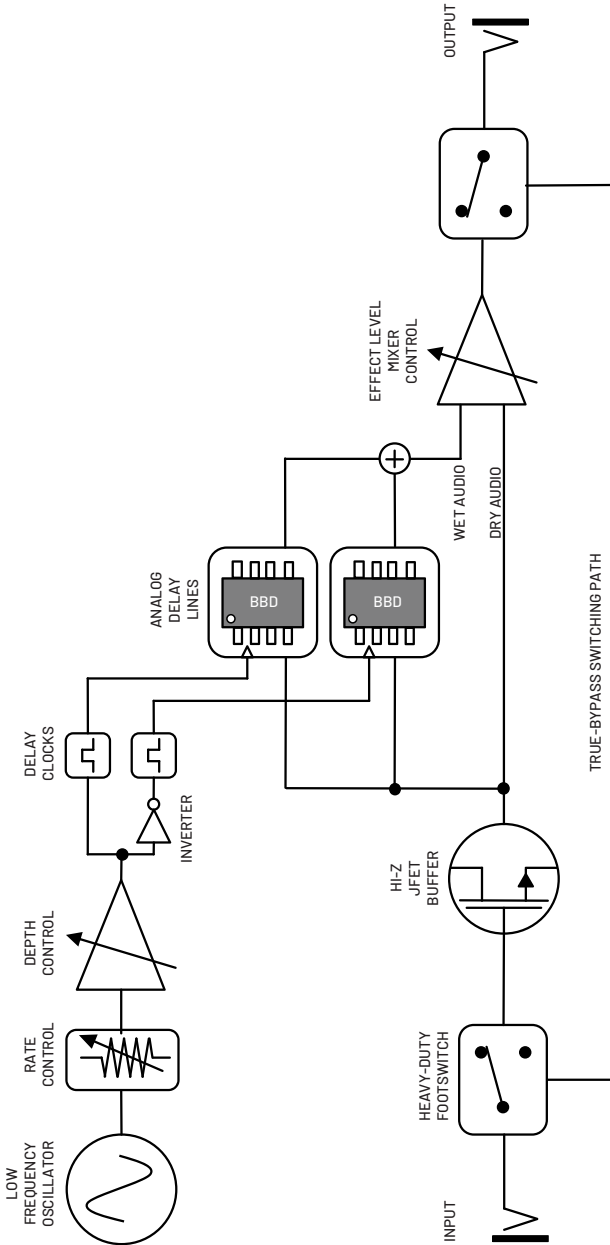



## Technical Specifications

Signal-to-Noise Ratio	82 dB (Effect Level 100% Wet) 94 dB (Effect Level 100% Dry)
Maximum Gain	+0 dB (Unity)
Maximum Input Level	1.1V RMS (3.0V peak-peak) before clipping (1.00% distortion), 100 Hz input
Frequency Response (Input Level 1.00 V peak-peak)	100 Hz – 5 kHz, $\pm 3.0$ dB (100% Wet) 20 Hz – 20 kHz, $\pm 0.5$ dB (100% Dry)
Impedances	1 M $\Omega$ (Input) 200 $\Omega$ (Output)
Power Requirements	Internal: 9V Battery External: 9V DC, $\geq 60$ mA, center negative Maximum Current Draw: 56 mA at 9V DC
Size (H x W x D)	2.2 in x 2.6 in x 4.5 in 56 mm x 66 mm x 114 mm
Weight	0.6 lb / 0.3 kg (approximately)

The Liquifier Analog Chorus is housed in a corrosion resistant, die-cast zinc chassis, so be sure to clean it with a dry, lint-free cloth. Never spray cleaning agents on the Liquifier Analog Chorus. Avoid abrasive cleansers which would damage the finish.

Ampeg continually develops new products and improves upon existing ones. For this reason, the specifications and information in this manual are subject to change without notice.

## Warranty and Support

Visit [WWW.AMPEG.COM](http://WWW.AMPEG.COM) to...

- (1) ...identify **WARRANTY** coverage provided in your local market. Please keep your sales receipt in a safe place.
- (2) ...**REGISTER** your product.
- (3) ...**CONTACT** Technical Support, or call 818-575-3600.

[www.ampeg.com](http://www.ampeg.com)  
Yamaha Guitar Group, Inc.  
26580 Agoura Road, Calabasas, CA 91302-1921 USA  
Rev. A



© 2019 Yamaha Guitar Group, Inc. All rights reserved.

Ampeg and the Ampeg logo are trademarks or registered trademarks of Yamaha Guitar Group, Inc. in the U.S. and/or other jurisdictions.